



2SD879

NPN EPITAXIAL SILICON TRANSISTOR

1.5V, 3V STROBE APPLICATIONS

DESCRIPTION

The UTC **2SD879** is a NPN epitaxial silicon transistor, designed for 1.5V and 3V strobe applications.

FEATURES

- * In applications where two NiCd batteries are used to provide 2.4V, two **2SD879s** are used.
- * The charge time is approximately 1 second faster than that of germanium transistors.
- * Less power dissipation because of I_{WO} Collector-to-Emitter Voltage $V_{CE(SAT)}$, permitting more flashes of light to be emitted.
- * Large current capacity and highly resistant to break-down.
- * Excellent linearity of h_{FE} in the region from low current to high current.

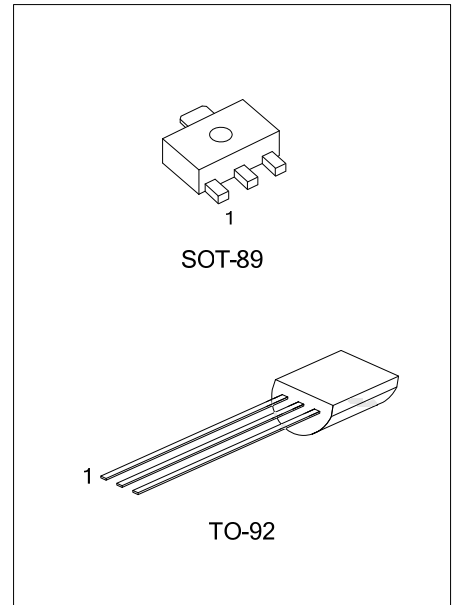

ORDERING INFORMATION

Ordering Number		Package	Pin Assignment			Packing
Lead Free	Halogen Free		1	2	3	
2SD879L-AB3-R	2SD879G-AB3-R	SOT-89	B	C	E	Tape Reel
2SD879L-T92-B	2SD879G-T92-B	TO-92	E	C	B	Tape Box
2SD879L-T92-K	2SD879G-T92-K	TO-92	E	C	B	Bulk
2SD879L-T92-R	2SD879G-T92-R	TO-92	E	C	B	Tape Reel

Note: Pin Assignment: E: Emitter C: Collector B: Base

<p>2SD879L-AB3-R</p> <p>(1) Packing Type (2) Package Type (3) Lead Free</p>	<p>(1) R: Tape Reel, B: Tape Box, K: Bulk (2) AB3: SOT-89, T92: TO-92 (3) G: Halogen Free, L: Lead Free</p>
---	---

■ ABSOLUTE MAXIMUM RATING ($T_A=25^{\circ}\text{C}$, unless otherwise specified)

PARAMETER	SYMBOL	RATINGS	UNIT
Collector-Base Voltage	V_{CBO}	30	V
Collector-Emitter Voltage	V_{CEX}	20	V
Collector-Emitter Voltage	V_{CEO}	10	V
Emitter-Base Voltage	V_{EBO}	6	V
Collector Dissipation	P_D	1	W
Collector Current (DC)	I_C	3	A
Collector Current (PULSE)	I_{CP}	5	A
Junction Temperature	T_J	150	$^{\circ}\text{C}$
Storage Temperature	T_{STG}	-55 ~ +150	$^{\circ}\text{C}$

Note 1. Pulse Condition -> 100 ms single pulse

2. Absolute maximum ratings are those values beyond which the device could be permanently damaged. Absolute maximum ratings are stress ratings only and functional device operation is not implied.

■ ELECTRICAL CHARACTERISTICS ($T_A=25^{\circ}\text{C}$, unless otherwise specified)

PARAMETER	SYMBOL	TEST CONDITIONS	MIN	TYP	MAX	UNIT
Collector-Base Voltage	V_{CBO}	$I_C=10\mu\text{A}, I_E=0$	30			V
Collector-Emitter Voltage	V_{CEX}	$I_C=1\text{mA}, V_{BE}=3\text{V}$	20			V
Collector-Emitter Voltage	V_{CEO}	$I_C=1\text{mA}, R_{BE}=\infty$	10			V
Emitter-Base Voltage	V_{EBO}	$I_E=10\mu\text{A}, I_C=0$	6			V
Base-Emitter Voltage	V_{BE}	$V_{CE}=-1\text{V}, I_C=-2\text{A}$		0.83	1.5	V
Collector Cut-Off Current	I_{CBO}	$V_{CB}=20\text{V}, I_E=0$			1	μA
Emitter Cut-Off Current	I_{EBO}	$V_{EB}=4\text{V}, I_C=0$			1	μA
DC Current Gain	h_{FE}	$V_{CE}=2\text{V}, I_C=3\text{A}$ (pulse)	140	210	400	
Collector-Emitter Saturation Voltage	$V_{CE(SAT)}$	$I_C=3\text{A}, I_B=60\text{mA}$ (pulse)		0.3	0.4	V
Current Gain Bandwidth Product	f_T	$V_{CE}=10\text{V}, I_C=50\text{mA}$		200		MHz
Output Capacitance	C_{OB}	$V_{CB}=10\text{V}, f=1\text{MHz}$		30		pF

Pulse: 1mS

UTC assumes no responsibility for equipment failures that result from using products at values that exceed, even momentarily, rated values (such as maximum ratings, operating condition ranges, or other parameters) listed in products specifications of any and all UTC products described or contained herein. UTC products are not designed for use in life support appliances, devices or systems where malfunction of these products can be reasonably expected to result in personal injury. Reproduction in whole or in part is prohibited without the prior written consent of the copyright owner. The information presented in this document does not form part of any quotation or contract, is believed to be accurate and reliable and may be changed without notice.